

Mauao

AWAITI PLATFORM | DEVELOPED CONCEPT | 7/11/22

NOT FOR CONSTRUCTION.

NOT FOR CONSTRUCTION

Platform Plan View

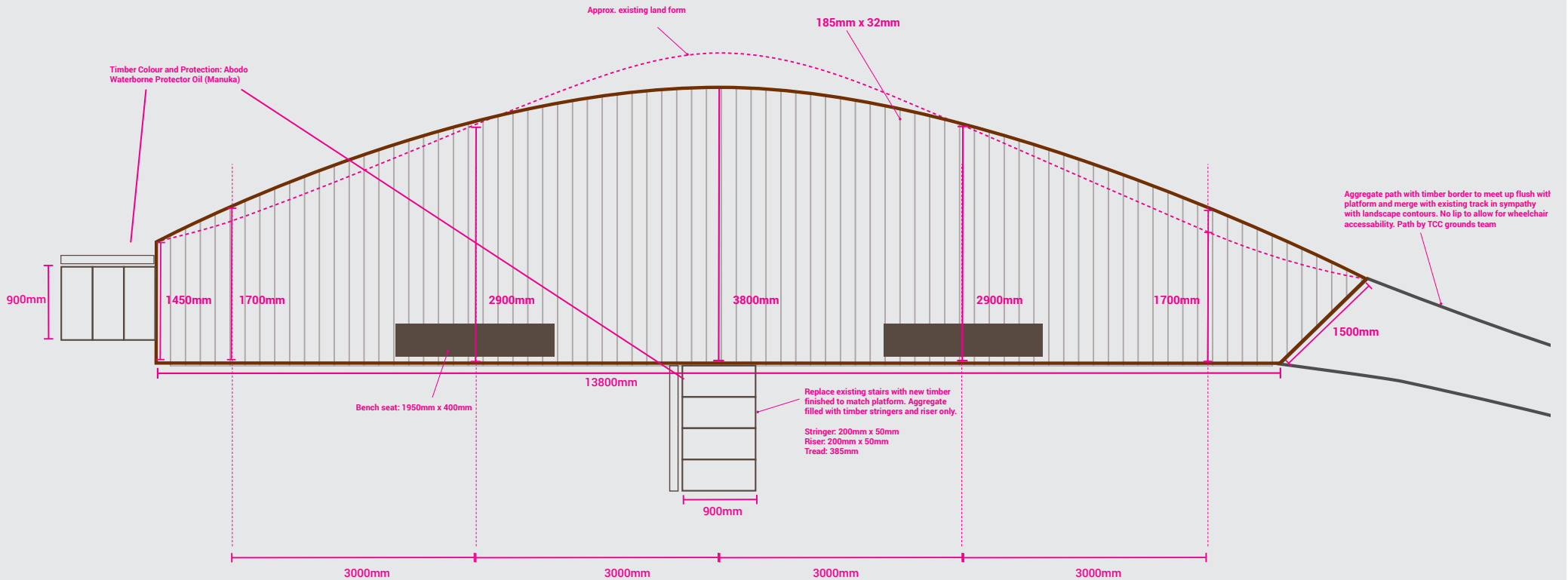

NOT FOR CONSTRUCTION

Platform Side Elevation

Levels and structural design to be specified by other.

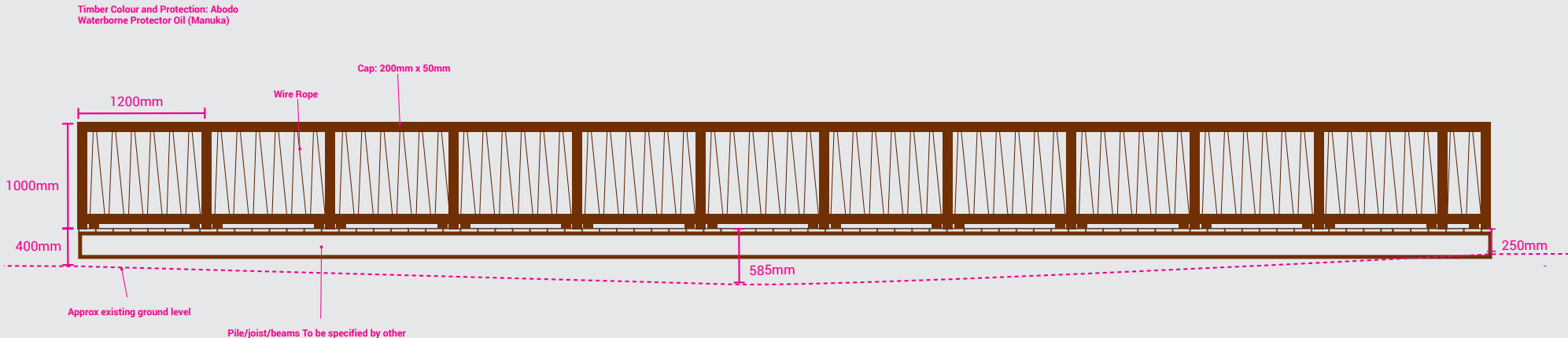

Hand Rail

Hand rail curved to match platform radius
TBD by other.

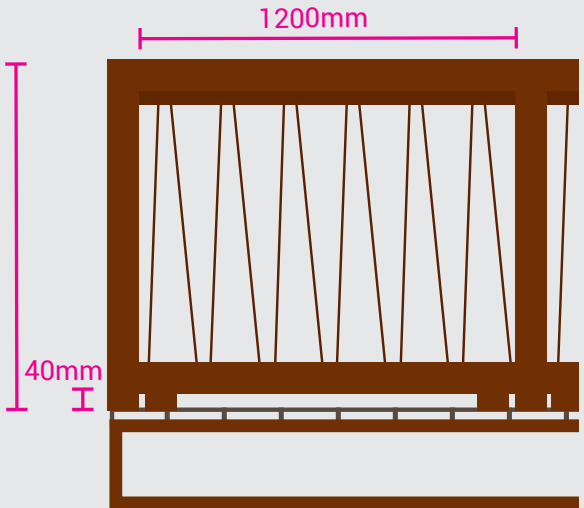
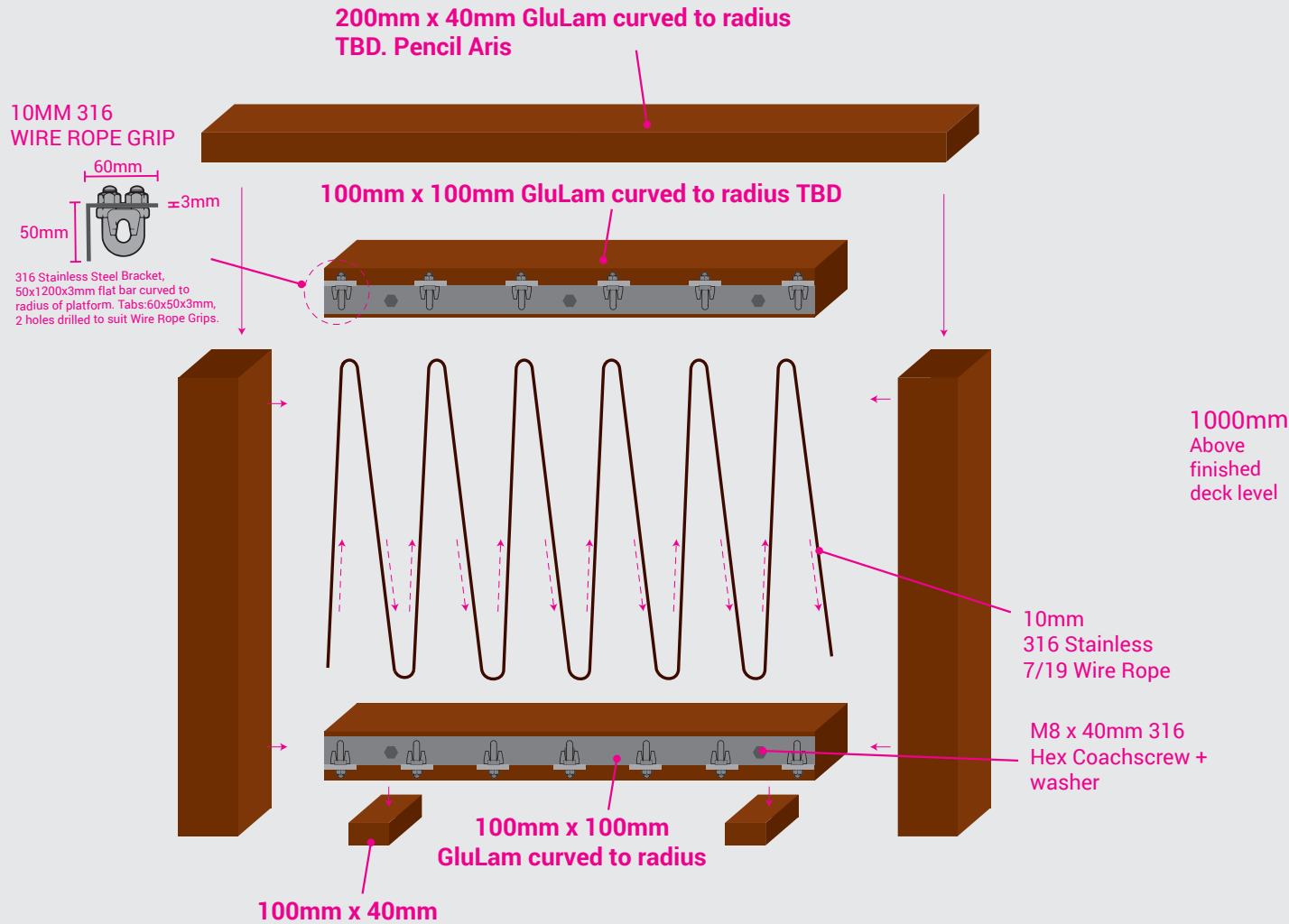

Bench Seats

Bench seats same as per updated mid-track seating mountain wide.

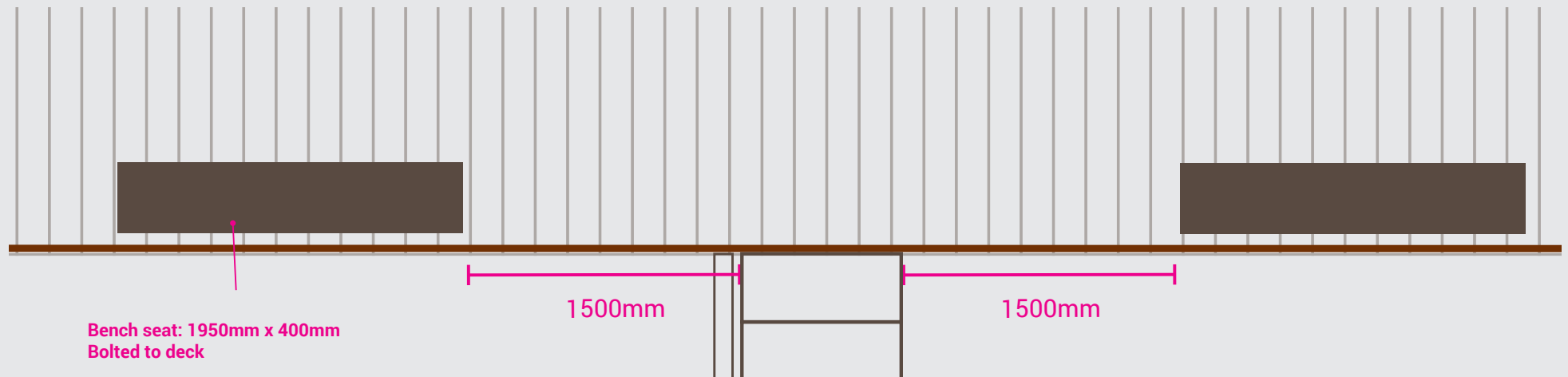

LAWCREATIVE DESIGN
SIGNS
WEB
PRINT

Contact Us

07 308 0095 [s 7\(2\)\(a\) - Privacy](#)

57 Commerce Street, Whakatane 3120, New Zealand

lawcreative.co.nz

WATERTANK TERRACING

DEVELOPED CONCEPT | OCTOBER 21

LAWCREATIVE DESIGN
SIGNS
WEB
PRINT

Hopukiore (Mount Drury Reserve),
Mount Maunganui

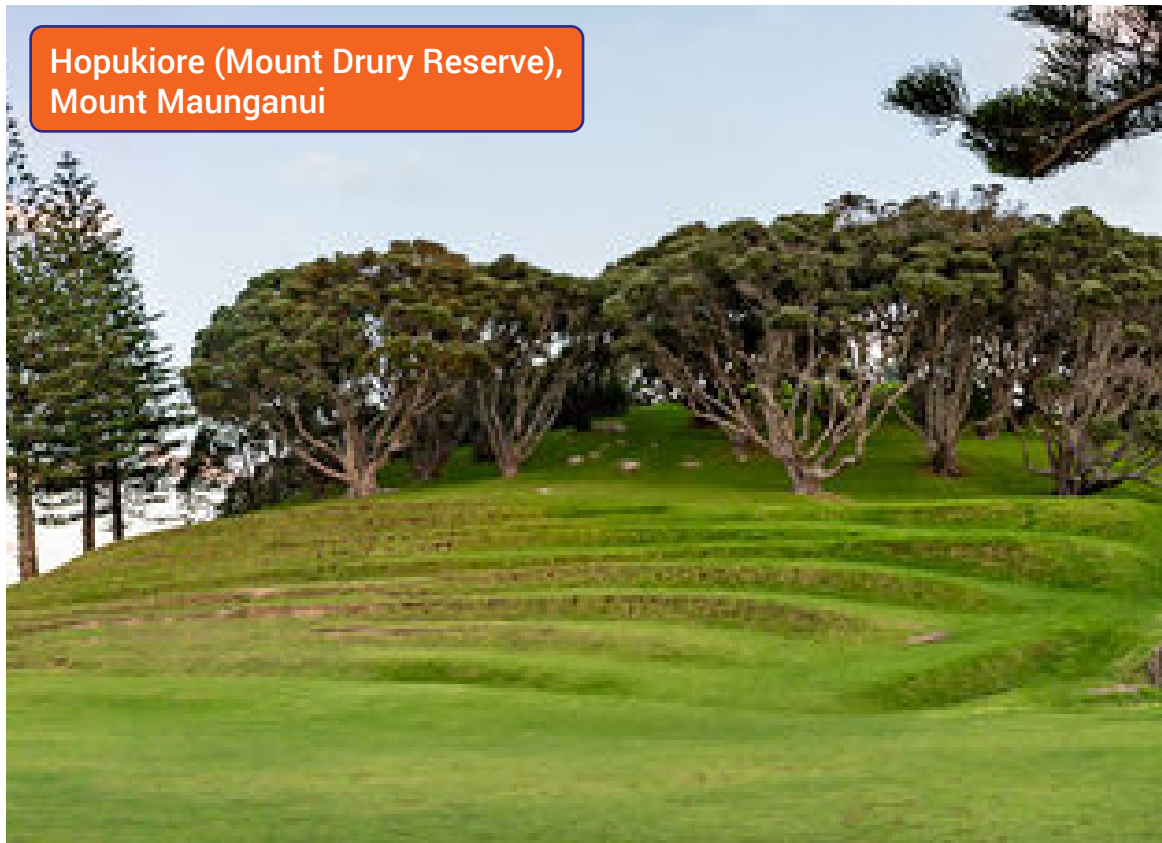

Mount Maunganui
Watertower



Plant species TBD
(Full width of embankment)

Approx 35m

5000mm

1700mm

1700mm



Terraces to be above existing
poly drain pipe.

Aggregate path

Existing Seat

2 steps to minimise
foot-fall erosion on bank.



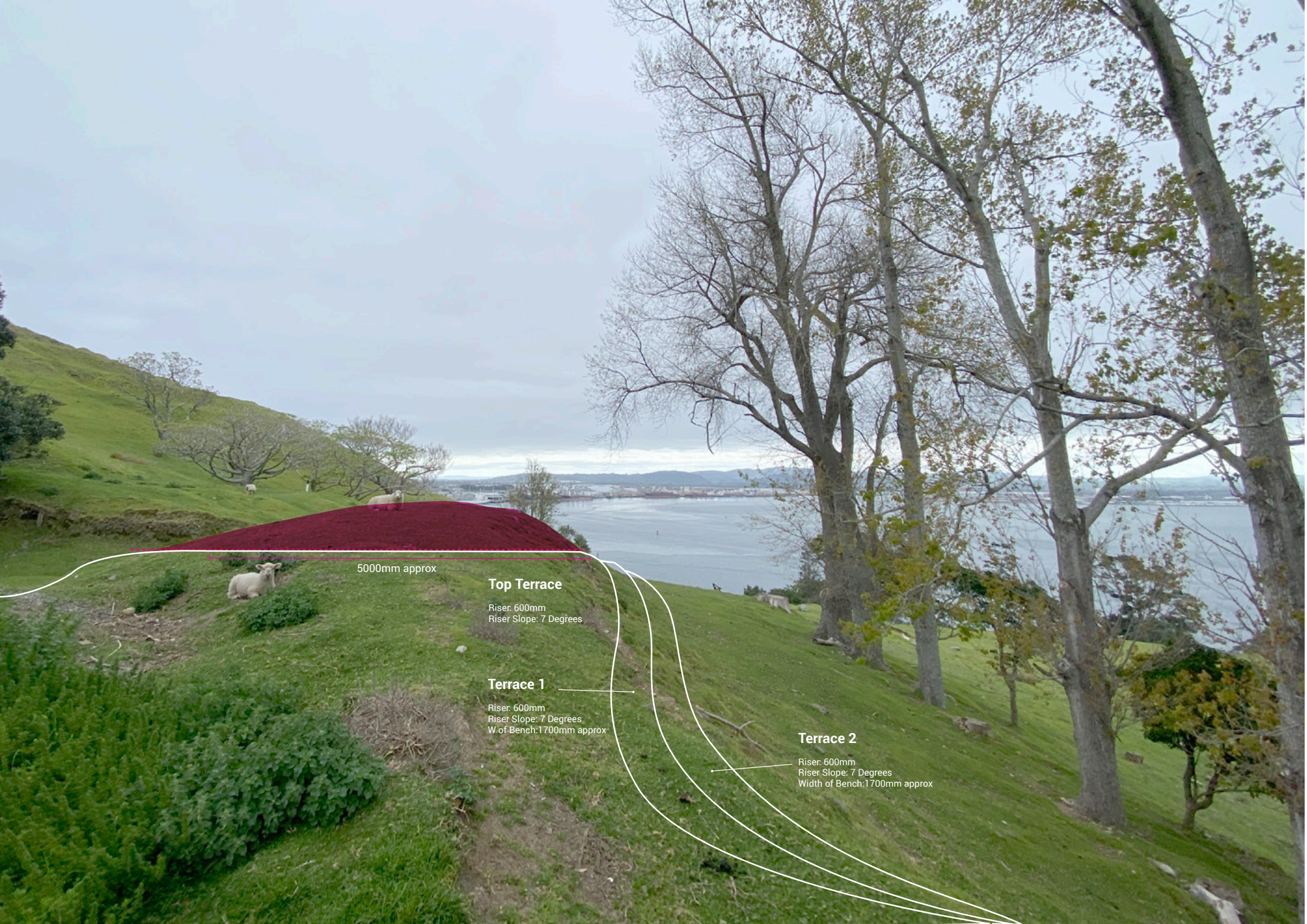

5000mm approx

Top Terrace

Riser: 600mm
Riser Slope: 7 Degrees

Terrace 1

Riser: 600mm
Riser Slope: 7 Degrees
W of Bench: 1700mm approx

Terrace 2

Riser: 600mm
Riser Slope: 7 Degrees
Width of Bench: 1700mm approx



Top Terrace

Terrace 1

Terrace 2

Interpretation Signage

Aggregate Path



Add basic stairs and simple aggregate path



Plant out bank to discourage access

2400mm

Fencing Locations

Please see site specific details with archaeological layer on the following pages.



1



1

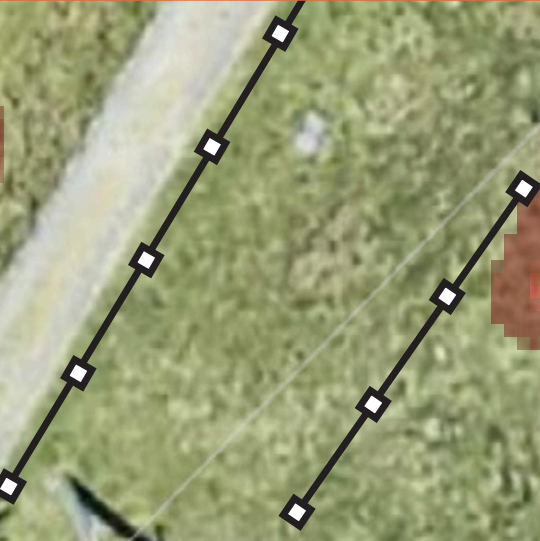

**TIERED
FENCING**

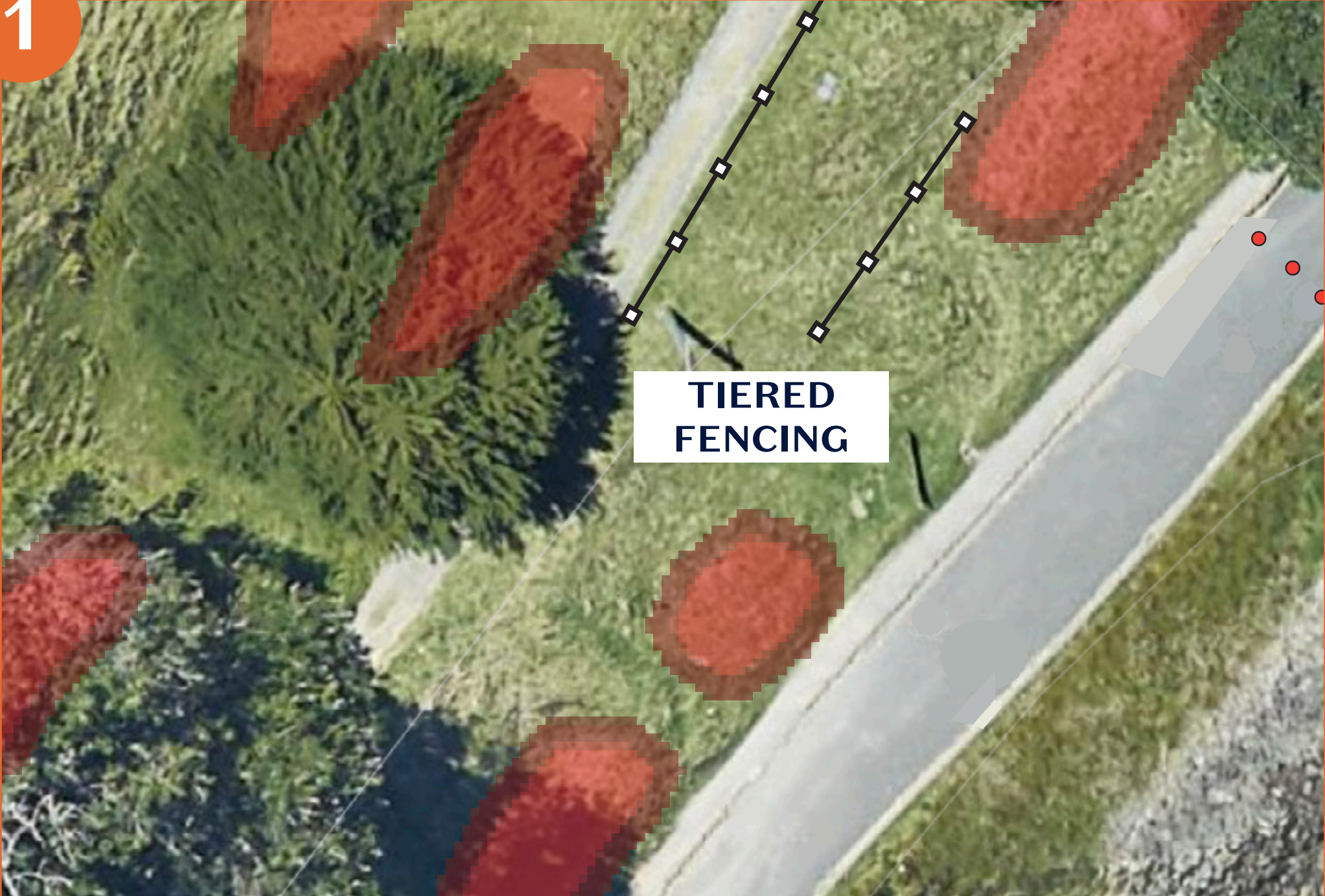

1



2



2

FENCE PÅ PERIMETER AT TRACK-SIDE



